

6.4 Mechanical, Electrical, and Plumbing Components

6.4.6 Ductwork

6.4.6.2 Air Diffusers

This category covers suspended air diffusers or mechanical registers, typically part of a suspended ceiling system.

Provisions

BUILDING CODE PROVISIONS

ASCE/SEI 7-10, *Minimum Design Loads for Buildings and Other Structures*, (ASCE, 2010), Chapter 13 requires that appurtenances to ductwork such as dampers, louvers, and diffusers be positively attached with mechanical fasteners. For air diffusers mounted in suspended acoustic lay-in tile ceiling systems, ASTM E580, *Standard Practice for Installation of Ceiling Suspension Systems for Acoustical Tile and Lay-in Panels in Areas Subject to Earthquake Ground Motions* (ASTM, 2010) requires that ceiling mounted air terminals or other services weighing less than 20 lb (9 kg) be positively attached to the ceiling suspension main runners or cross runners that have the same carrying capacity as the main runners.

RETROFIT STANDARD PROVISIONS

Suspended HVAC equipment in-line with ductwork, including air diffusers, are classified as force-controlled by ASCE/SEI 41-06, *Seismic Rehabilitation of Existing Buildings*, (ASCE, 2007). ASCE 41-06 requires compliance with the anchorage provisions of the standard when:

- The performance level is Immediate Occupancy.
- The performance level is Life Safety in high seismicity areas, if
 - The item weighs over 20 pounds and is mounted over 4 feet above the floor.
- The recommended evaluation procedure is to use a prescriptive approach, such as provisions in ASCE/SEI 7-10 Section 13.6.7.

Typical Causes of Damage

- Air diffusers may pose a falling hazard if they are not supported independent of the ceiling. The diffuser may separate from the attached duct and fail to operate as intended.

DAMAGE EXAMPLES



Figure 6.4.6.2-1 Air diffusers fell to the floor; ducts hanging through ceiling grid as a result of the 1994 Northridge Earthquake (FEMA 74, 1994).



Figure 6.4.6.2-2 HVAC diffuser attached to the structure with four vertical hangers; ceiling system was damaged beyond repair in the 2001 Peru Earthquake but none of the diffusers or lights fell. Ceiling was demolished prior to photo (Photo courtesy of Eduardo Fierro, BFP Engineers).

Seismic Mitigation Considerations

- Requirements for ceiling mounted services in suspended acoustic ceilings are covered in ASTM E580, *Standard Practice for Installation of Ceiling Suspension Systems for Acoustical Tile and Lay-in Panels in Areas Subject to Earthquake Ground Motions* (ASTM, 2010). Air diffusers and other ceiling-mounted services weighing less than 20 lb must have positive attachment to the ceiling grid. In addition to positive attachment to the grid, services weighing between 20 lb and 56 lb must have two 12 gauge safety wires connected to the structure above or to the ceiling hanger wires to prevent them from falling. Two diagonally opposite vertical safety wires can keep them from posing a risk to occupants below. Services weighing above 56 lb must be supported directly from the structure above by approved hangers; in some cases this can be accomplished with 4 taut 12 gauge wires, one located at each corner of the service. While ASTM E580 does

not require safety wires for items weighing less than 20 lb, use of at least one wire may be good practice considering the number of diffusers that have come down in recent earthquakes.

- Only intermediate duty or heavy duty grid may be used to support suspended acoustic ceilings with lights and mechanical services attached. For Seismic Design Category D, E & F, only heavy duty grid may be used. See Section 6.3.4.1 for additional ceiling requirements. For an existing unbraced ceiling, the addition of four diagonal wire braces at each corner of diffusers will limit horizontal movement of the diffuser and prevent impact with other suspended items. Diffuser restraints should be coordinated with the lateral restraints for the ceiling grid and may require engineering expertise.
- Do not brace diffusers to ducts, piping, or other nonstructural items.

MITIGATION DETAILS

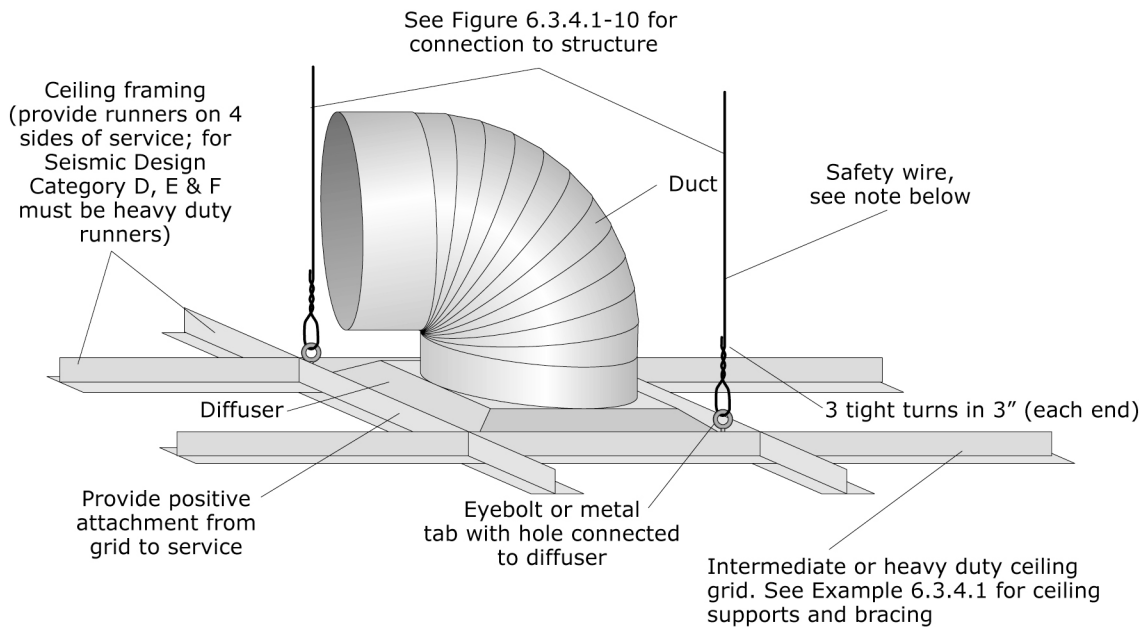

Notes:

- For services < 20# provide 1 - #12 gauge safety wire (may be slack)
- For services 20# - 56# provide 2- #12 gauge safety wires (may be slack)
- For services > 56# provide 4 taut wires or other direct support to structure

Figure 6.4.6.2-3 Ceiling-mounted diffuser (NE, ER).