

6.3 Architectural Components

6.3.1 Exterior Wall Components

6.3.1.5 Glass block

Glass block, or glass unit masonry, is used to construct a variety of nonbearing walls or used as nonbearing infill in window openings. If not properly detailed to accommodate movement, glass block units may break and pose a falling hazard.

Provisions

BUILDING CODE PROVISIONS

The design provisions for the design and construction of glass unit masonry are empirical and prescriptive, with limits on panel size, the spacing between structural supports, deflections of supports, and prescriptive joint reinforcing requirements. There are additional code limitations on material properties of the glass unit masonry, sealant, and mortar; and properties, spacing, and details of anchorage hardware; and spacing and details of expansion joints.

- Design requirements are found in TMS 402–11 / ACI 530–11 / ASCE 5–11, *Building Code Requirements and Specification for Masonry Structures and Related Commentaries* (MSJC, 2011), Chapter 7. There are also limitations on the use of glass block in Section 2110 of the 2012 IBC, *International Building Code*, (ICC, 2012)..
- Seismic design forces on the nonbearing wall assembly are determined from ASCE/SEI 7–10, *Minimum Design Loads for Buildings and Other Structures*, (ASCE, 2010), Chapter 13, Nonstructural Components.

RETROFIT STANDARD PROVISIONS

ASCE/SEI 41–06, *Seismic Rehabilitation of Existing Buildings* (ASCE, 2007) classifies glass block as primarily deformation sensitive in the in–plane–, and acceleration sensitive in the out–of–plane direction. Glass block is subject to the requirements of ASCE/SEI 41–06 when:

- The performance level is Immediate Occupancy or Life Safety.
- The performance level is Hazards Reduced and glass block is located over areas of public access or egress.

Acceptance criteria requires conformance with in–plane drift limits and out–of–plane forces.

The rehabilitation approach depends on the size of the individual walls. Walls less than 144 SF or 15 feet in any dimension may be retrofitted using prescriptive procedures. Larger walls must be analyzed,

Typical Causes of Damage

- Glass block panel assemblies are subject to both in-plane and out-of-plane failures. If the glass block panels are not reinforced and isolated from the movement of the structural surround or structural supports, the panel consisting of brittle glass blocks may be damaged. Older glass block panels may be installed with rigid mortar along all four sides and in the mortar joints. Damage to these rigid installations, or installations without the capacity to accommodate seismic deformations, may result in glass block breakage, falling glass block units, or possibly failure of the whole panel.
- If glass block panels are rigidly attached at the sill with mortar, but allowed to slip along the top and sides, and installed with panel reinforcing in alternate mortar joints, there may be damage to the panel anchors, angles, or channels surrounding the panel. The fire-rating or weatherproofing may also be compromised and should be inspected if there are signs of movement.
- A survey of glass block installations after the 1994 Northridge Earthquake found that glass block panels installed per the UBC provisions since the late 1970's had performed well (Hart, 1994).

DAMAGE EXAMPLES



Figure 6.3.1.5-1 Damage to glass block in building with reinforced concrete frame and concrete masonry infill in the magnitude-7 2010 Haiti Earthquake (Photo courtesy of Eduardo Fierro, BFP Engineers). Note some blocks failed at rigid mortar joints and stayed in the frame, others fell out of the frame, and others broke in place. This building also suffered structural damage.



Figure 6.3.1.5-2 Damage to glass block with rigid mortar on all sides and in all joints in the 2010 Chile Earthquake (Photo courtesy of Eduardo Fierro, BFP Engineers). About 25% of the glass block units are cracked or broken but entire panel will need to be removed and replaced.



Figure 6.3.1.5-3 Damaged glass block panel from the Los Angeles Hospital in the 2010 Chile Earthquake; relatively new hospital building that had to be evacuated for repairs (Photo courtesy of Bill Holmes, Rutherford & Chekene). Blocks were installed with steel reinforcing bars in the top and bottom horizontal joints.

Seismic Mitigation Considerations

- The design of glass block panels must meet the applicable code requirements for glass masonry construction. The glass block panel should be isolated for seismic, wind and thermal movement from the nonstructural surround, and the nonstructural surrounding wall should be isolated from the seismic inter-story drift of the structure.
- For seismic resistance, the panels must be supported for both in-plane- and out-of-plane loads but should be isolated from the movement of the surrounding structure. Glass block units are inherently brittle and must be supported in a manner that does not allow structural loads from the building to be transmitted to the glass blocks. This typically involves providing a rigid mortar attachment to the sill at the bottom of the panel and providing slip joints along the top and sides. In addition, horizontal reinforcing is placed in alternate mortar joints. Typical glass block panel details are

shown in Figure 6.3.1.5–6. Slip joints at the top and sides may be accomplished with steel angles, steel channels, or panel anchors (see three alternate head details in Figure 6.3.1.5–7). Jamb details are similar.

- Note that the fire-rated head detail A in Figure 6.3.1.5–7 is very similar to Figure 6.3.2.1–9 used for full-height heavy partitions. This type of detail with steel angles provides the most robust seismic restraint where large displacements are expected.
- Special care must be taken to detail glass block panels on intersecting planes such as corners or reentrant corners. Simultaneous motion in two directions makes these joints particularly vulnerable to damage.
- Glass block vendors often have proprietary hardware, standard specifications, and standard downloadable details available to assist designers. Manufacturer's standard slip joint details are typically designed to accommodate thermal expansion and wind forces and may not have not been explicitly designed for seismic deformations. Thus, these details should be used with caution if large inter-story drifts are expected.
- It may be prudent to avoid using glass block near exits and to restrict pedestrian access below or adjacent to a large expanse of glass block by providing a barrier or wide landscaping strip.

MITIGATION EXAMPLES



Figure 6.3.1.5-4 Use of glass block panels for select exterior and interior walls at the North Hollywood Police Station in California, utilizing standard details provided by Pittsburgh Corning Glass (Photo courtesy of Pittsburgh Corning Corporation).



Figure 6.3.1.5-5 Glass block panels divided into numerous subpanels at the Chula Vista Police Headquarters, California (Photo courtesy of Pittsburgh Corning Corporation). In addition, the nonbearing glass block panel partition wall is isolated from seismic movement of the building structure.

MITIGATION DETAILS

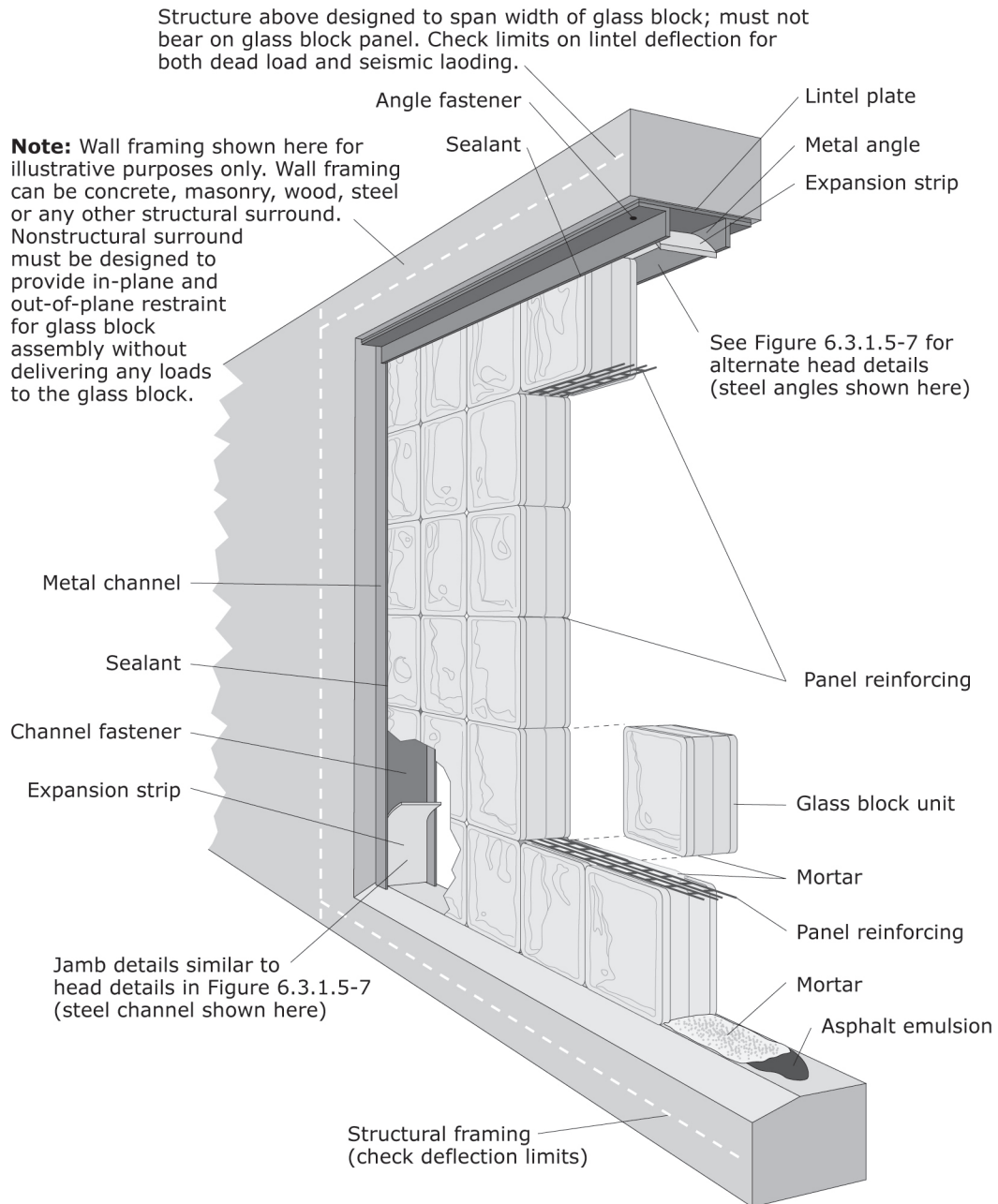
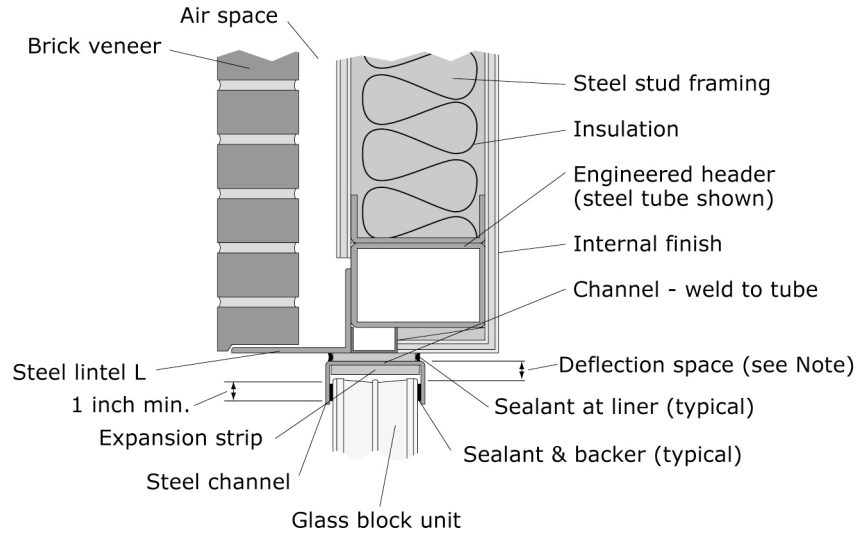
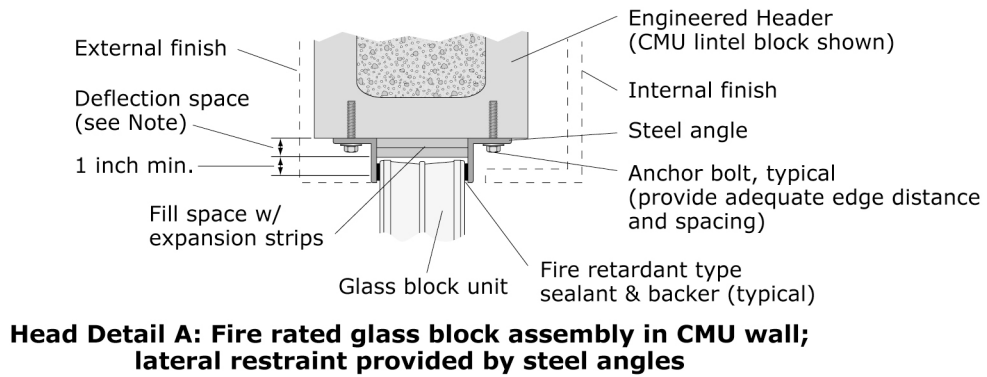
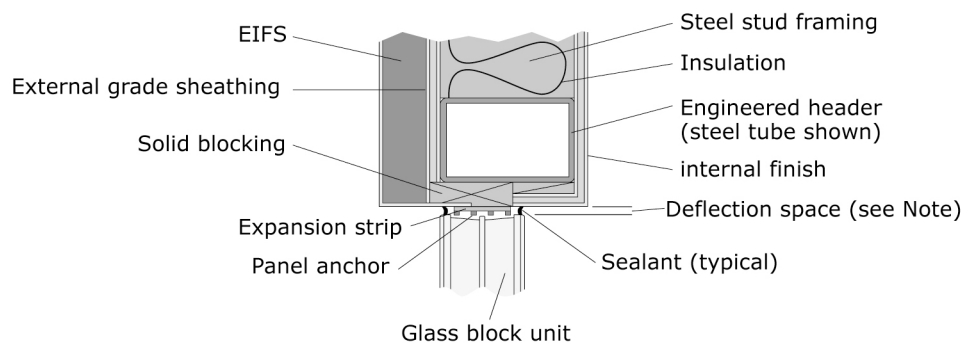

Figure 6.3.1.5-6 Typical glass block panel details (shown here with steel angles or channels to provide lateral restraint (ER)).



Head Detail B: Non-rated glass block assembly in steel stud wall with brick veneer; lateral restraint provided by steel channel



Head Detail C: Non-rated glass block assembly in steel stud wall with lightweight finish; lateral restraint provided by panel anchors

Note: The dimension "deflection space" for both jamb and head joints is determined by the anticipated deflection (gravity, seismic, thermal, etc.) of the structural members adjacent to the glass block panel.

Figure 6.3.1.5-7 Alternate head details for glass block panels (jamb details similar) (ER).