

6.4 Mechanical, Electrical, and Plumbing Components

6.4.2 Storage Tanks and Water Heaters

6.4.2.4 Water Heaters

This category includes residential or small commercial water heaters. Most water heaters rest on the floor although smaller units may be wall- or shelf-mounted. Tankless water heaters are often wall-mounted.

Provisions

BUILDING CODE PROVISIONS

Seismic loads for water heaters are determined using ASCE/SEI 7-10, *Minimum Design Loads for Buildings and Other Structures*, (ASCE, 2010), Chapter 13. The principal objective is to prevent the water heater from sliding or overturning. They may be floor mounted, wall mounted, or suspended from the level above.

- ASCE/SEI 7-10 requires anchorage design for all equipment in Seismic Design Categories D, E, and F if the equipment weighs over 400 pounds. Lighter components may be exempt if the component Importance Factor $I_p = 1.0$.
- Items that are exempt from the anchorage design requirements must still be positively anchored to the structure. The anchorage need not be designed or detailed on the construction documents. Exempt items must also be provided with flexible connections between the equipment and associated pipes or conduits.

RETROFIT STANDARD PROVISIONS

ASCE/SEI 41-06, *Seismic Rehabilitation of Existing Buildings*, (ASCE, 2007) contains specific requirements retrofit of water heaters. Compliance with the anchorage provisions of the standard is required when:

- The performance level is Immediate Occupancy.
- The performance level is Life Safety in High Seismicity areas and the water heater is more than 6 feet in height, or the unit is gas-fired.

Water heaters with a capacity less than 100 gallons may be retrofitted using prescriptive approaches. Larger water heaters must meet the force provisions of the standard.

Typical Causes of Damage

- Unanchored or poorly anchored tanks may slide or overturn.
- Even if the restraint is strong enough to prevent complete overturning, if it is not rigid enough, the connections to gas and water lines may be damaged by tank movement and lead to fire or to water leakage

DAMAGE EXAMPLES



Figure 6.4.2.4-1 Unanchored water heaters overturned (Photo courtesy of Mason Industries).



Figure 6.4.2.4-2 Water damage at the Talca Hospital in the 2010 magnitude-8.8 Chile Earthquake; water leaking from tank at right. This building was closed due to nonstructural damage, dominated by water damage (Photos courtesy of Bill Holmes, Rutherford & Chekene).



Figure 6.4.2.4-3 Damaged water heater in the 2010 magnitude-6.5 Eureka Earthquake. The water heater strap pulled out from the supporting concrete wall as a result of inadequate anchorage. The tank moved sufficiently to break interconnected water lines which were rigidly connected to the tank.

Seismic Mitigation Considerations

- Details shown are for tanks resting on the floor adjacent to a structural wall. Where the water heater is not located adjacent to a wall, it may be necessary to construct a frame around the tank or adjacent to the tank to provide anchorage.
- Flexible connections should be provided for the gas and water lines.
- Provide noncombustible spacers between the tank and wall for older units; newer units often have insulation inside the housing as part of the assembly and do not require the additional spacers.
- Larger tanks may be floor-mounted as shown for flat bottom tanks in Section 6.4.2.2 or as pictured in Figure 6.4.2.4–5.
- See also *Guidelines for Earthquake Bracing of Residential Water Heaters* (California Department of General Services, 2005c) online at www.documents.dgs.ca.gov/dsa/pubs/waterheaterbracing_11_30_05.pdf for additional information.

MITIGATION EXAMPLES



Figure 6.4.2.4-4 Corner installation using a commercially available strap; note flex copper tubing for water hook up (Photo courtesy of Cynthia Perry, BFP Engineers).



Figure 6.4.2.4-5 Base-mounted water heater located in a school; equipment supplied with metal base for mounting (Photo courtesy of EQE for the Salt Lake City School District).

MITIGATION DETAILS

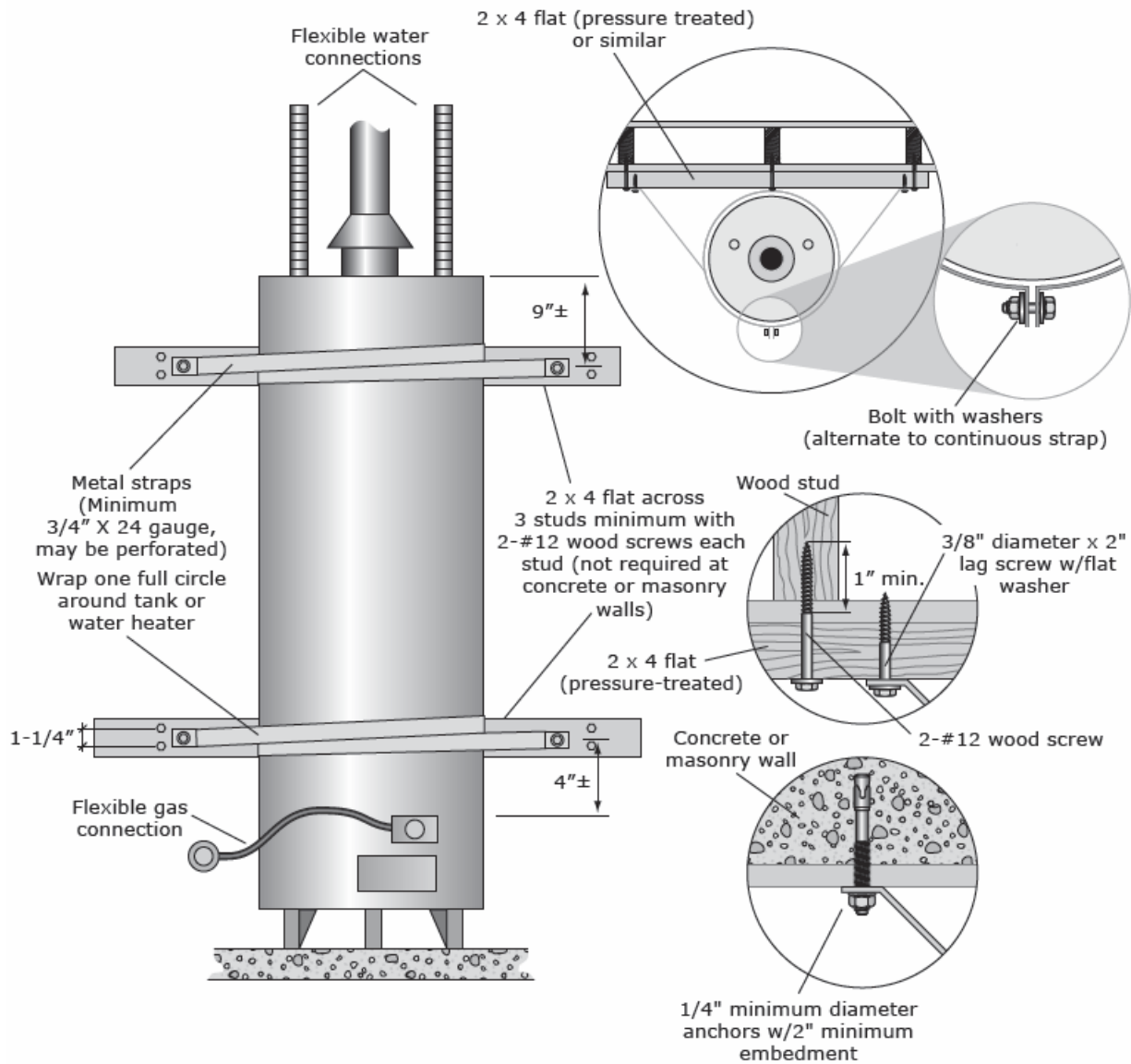

Figure 6.4.2.4-6 Water heater (PR).

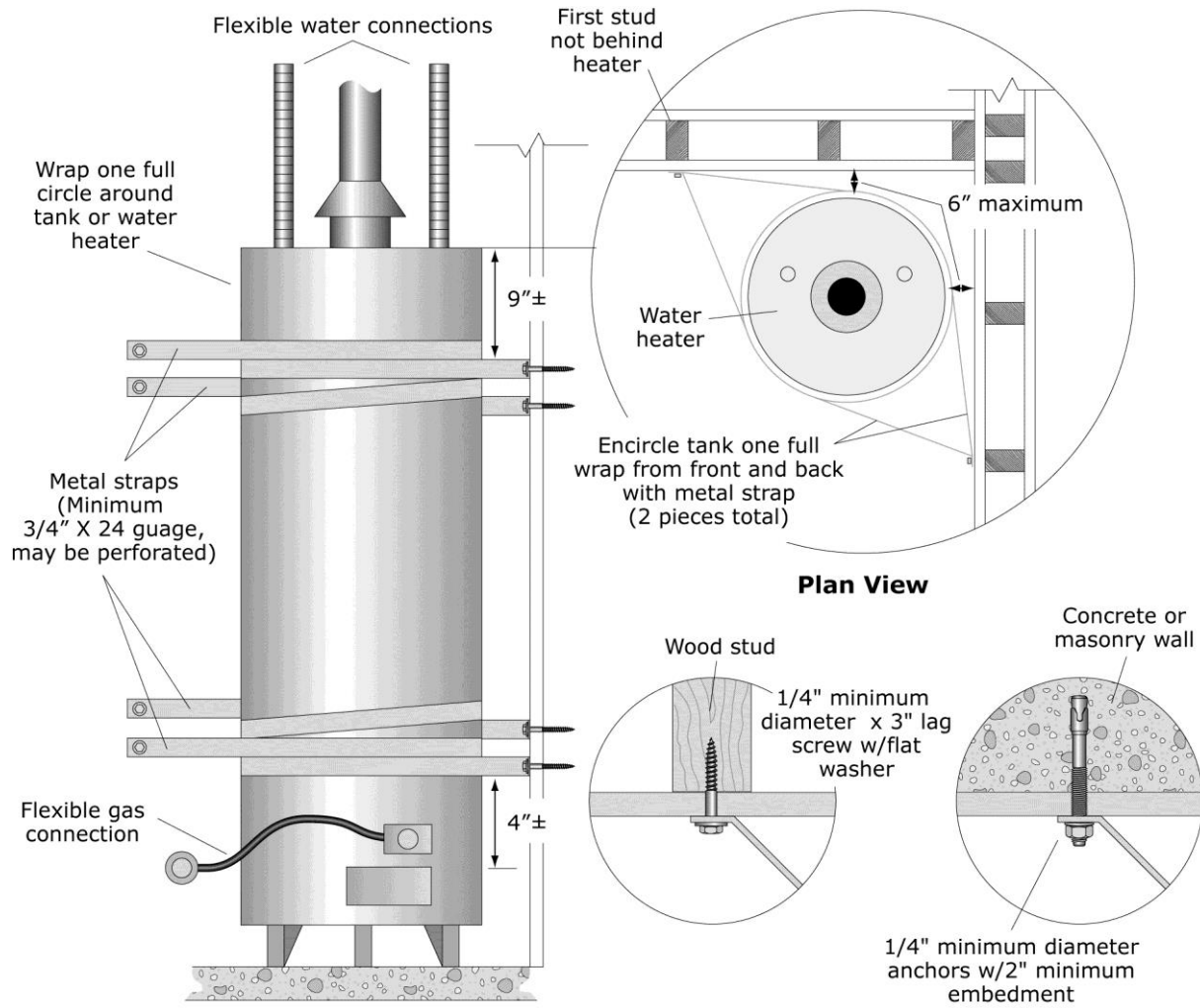

Figure 6.4.2.4-7 Water heater - corner installation (PR).